

OGRPHY®

PRODUCT MANUAL

LiFePO4 (12V 50Ah)

OGRPHY



OGRPHY

Shenzhen Ogrphy Technology Co., Ltd

www.ogrphytech.com
service@ogrphytech.com

www.ogrphytech.com service@ogrphytech.com



THANK YOU FOR CHOOSING OGRPHY.

Pls read the product manual carefully before using the unit. Using the LiFePO4 battery in a proper way helps you maximum its performance, extend cycle life, and avoid unnecessary damage.

Ready? Start to create your green and powerful life with Ogrphy now!

CONTENTS

PRODUCT SPECIFICATIONS	01
CAUTIONS&WARRANTY	02
Cautions	02
Warranty	02
CHARGE&DISCHARGE	03
Recommend Charging Method	03
Charging/Discharging Temperature Requirement	03
State of Charge (SOC)	04
Depth of Discharge(DOD)	04
CONNECTION TIPS	05
Premise of Connection	05
Limitation for Series/Parallel Connection	05
Parallel/Series Connection	06
Connection Both in Parallel&Series	06
MAINTENANCE AND STORAGE	06
HOW TO ACTIVATE THE BATTERY WHEN BMS CUT IT OFF FOR PROTECTION?	07

PRODUCT SPECIFICATIONS



12V 50Ah

Nominal Voltage	12.8V
Charge Voltage	14.4±0.2V
Nominal Capacity	50Ah
BMS Board	50A
Energy	640Wh
Max Load Power	640W
Max Continuous Charging Current	25A
Max Continuous Discharging Current	50A
Max Discharging Current	150A(Lasts for 5-10 seconds)
Connect in Series/Parallel	Max 4 in Series and 4 in Parallel (Total 16 batteries)
Cycle Life	2000-5000 times
Working Temperature	Charging Temperature: 0°C to 55°C Discharging Temperature: -20°C to 60°C
Weight	12.3lbs
Dimension	7.8*6.5*6.7inch
Recommend Solar Panel Configuration (Fully charges with effective sunshine 4.5h/day)	150W
Wire(s) for Series & Parallel Connection / Loading	8AWG

CAUTIONS&WARRANTY

CAUTIONS:

- DO NOT short circuit
- DO NOT reverse charging
- DO NOT disassemble
- DO NOT drop
- DO NOT expose to heat or immerse in water
- Away from kids and pets

WARRANTY:

We commit you five years warranty for each Ogrphy battery, only if the battery is being correctly used according to our guidance and instructions. If you need our assistance, pls contact our service team for support. We promise to reply you in 24 hours.

If the battery can not be fixed, pls contact our customer service for prepaid return label, then send back the battery back to our warehouse. After we receive the return item, we will arrange the replacement or refund.

WARRANTY CARD

Thank you for purchasing Ogrphy LiFePO4 battery.

Fill in for future reference

Date Purchased: _____ Tel: _____

Order No.: _____ Email Add: _____

CHARGE&DISCHARGE

Recharge the battery at 20% capacity left will increase the cycle times of the lifepo4 battery.

RECOMMEND CHARGING METHOD:

Option 1: Use lithium iron phosphate battery charger, with charging voltage 14.2V-14.6V

Option 2: Use inverter/controller, select 12V lithium iron phosphate battery mode and set as below,

SETTING for CHARGE CONTROLLER:

CHARGE

- Charging limit voltage: 14.6V
- Overvoltage disconnect voltage: 15V
- Overvoltage re-connection voltage: 14.2V

DISCHARGE

- Low voltage disconnection voltage: 10.8V
- Low voltage reconnection voltage: 11.6V
- Undervoltage warning voltage: 12.4V

CHARGING/DISCHARGING TEMPERATURE REQUIREMENT:

Charging Temperature: 0°C to 55°C

Discharging Temperature: -20°C to 60°C

CHARGE&DISCHARGE

STATE OF CHARGE(SOC)

It may have a margin of error of 10% in practice, below parameters are just for reference only. The battery needs to be tested at rest(with zero current) after 15mins of disconnecting from charge&load.

Voltage(v)	Electricity(SOC)
13.4~13.8	100%
13.38	90%
13.37	80%
13.37	70%
13.26	60%
13.23	50%
13.21	40%
13.15	30%
13.04	20% (Recommend recharge voltage)
12.91	10%
11.85	0%

DEPTH OF DISCHARGE(DOD)

DOD 100% (charging 100%, and discharging 100%), the battery gets 2000 circles
DOD 80% (charging 100%, and discharging 80%), the battery gets 5000 circles

CONNECTION TIPS

PREMISE OF CONNECTION:

To connect batteries in series or/and in parallel, batteries are supposed to be

- with same capacity (Ah)
- from same brand (in case of different BMS)
- in short purchase interval (within one month)

Before connected in series/in parallel, please balance the voltage of the batteries:

Connect the batteries in parallel until the difference of their voltage is lower than 30mV.

LIMITATION FOR SERIES/PARALLEL CONNECTION

Support connection up to 4 series or 4 parallel.

E.g, connect 4 pcs 12V 50Ah batteries in series, you'll got 48V 50Ah battery system;
connect 4 pcs 12V 50Ah batteries in parallel, you'll got 12V 200Ah battery system

PARALLEL/SERIES CONNECTION

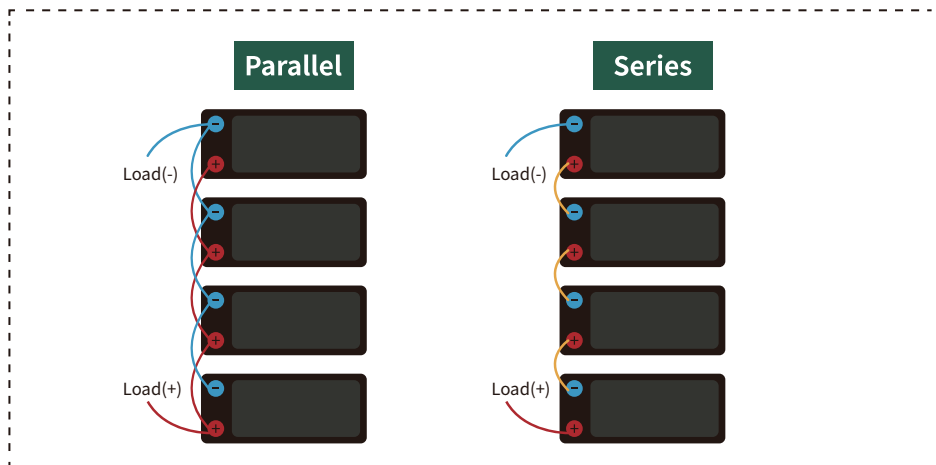

CONNECTION BOTH IN PARALLEL&SERIES

Pls be reminded 48V is the maximum for connection both in series and parallel battery system.

- Step1 Connect the batteries in parallel
- Step2 Connect the parallel battery systems in series

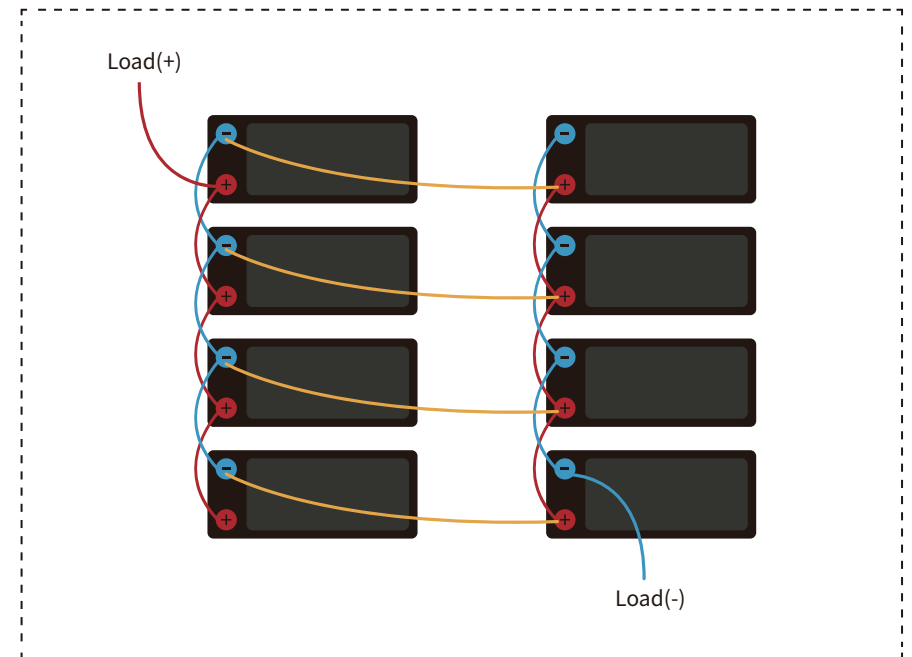

MAINTENANCE AND STORAGE:

Charge your battery every 3 months if it hasn't been used for a long time

Storage Environment: 0 °C to 45 °C@60±25% relative humidity

HOW TO ACTIVATE THE BATTERY WHEN BMS CUT IT OFF FOR PROTECTION?

The built-in Battery Management System(BMS) provides protection for overcharge, over-discharge, overload, overheating and short circuit.

If the BMS has cut off the battery for protection, cut off the load and put the battery aside for 30 minutes. The battery will automatically recover itself to normal voltage then, and **you may use the battery after it fully charged.**

If the battery is unable to recover itself and its voltage is too low to hold a charge, you can activate it in below ways:

- ① Use the charger with 0V charging function to fully charge the battery
- ② Parallel with another 12V lithium battery(or 12V-14.6V lead-acid battery) for a minute
- ③ Use 12V/18V solar panel to charge the battery for about 3 seconds

**For Ogrphy customers
who request a warranty, return or exchange
We are here to help**

 service@ogrphytech.com